

UNIVERSITY OF JORDAN
Electrical Engineering Department
Measurements & Control Lab. 0908448
Experiment no. 3
Introduction to Fuzzy Logic Control

Introduction

Traditional logic is based upon the idea that problems can be reduced to a series of statements which are either true or false. However, many everyday situations are not suited to this logical form. Many questions exist where the answer is neither 'yes' nor 'no', but somewhere an in-between answer is required. For example, on a pleasant summer's day, the statement 'the temperature is too high' is neither true nor false. The response to the question requires us to grade the response to indicate that the temperature is neither too hot nor too cold. Common sense tells us that there are grades of meaning or qualified responses to most problems. Philosophers and mathematicians have considered forms of logic for this situation by introducing concepts such as 'vagueness' and multi-valued logic. The topic of fuzzy logic is one way of dealing with things where there is vagueness, by allowing degrees of certainty to be associated with the answer to a question.

Fuzzy Control

The most useful application of fuzzy logic is in the control of events where precise regulation of a process variable is not a primary requirement. As such, the most suitable applications are where there are qualitative requirements for a satisfactory control action. Specifically, these qualitative requirements can be easily stated as fuzzy logic rules and then embedded in a fuzzy logic control algorithm. In this connection, fuzzy logic controllers are widely used to operate the automatic functions of washing machines, video recorders, compact disk players, air conditioning systems, cameras and so on.

It is also possible to use fuzzy logic in industrial feedback control problems that are conventionally solved using experienced human operators who have manual control over a complex process. The procedure followed is to put the operator's control procedure into a fuzzy rule set and hence develop a fuzzy control system. Specifically, the fuzzy logic designer notes the heuristic actions of a human operator when they control a process and writes down the corresponding fuzzy rule. By careful observations of a skilled operator, a complete set of fuzzy rules is obtained which hopefully will reproduce the best performance of the human operator. The result is an 'intelligent' control system which is obtained without reference to control systems theory. This is a simplified view of how a fuzzy controller is prepared, but the basic idea is that intuition and common sense ideas are used.

The intuitive nature of such control systems has a great appeal to many users. Unfortunately, the set of rules for such a system may be very large indeed and must be carefully checked because human operators are often very subtle in their actions and it can be difficult to translate their nuances into fuzzy logical statements. Depending upon the complexity of the process to be controlled, the construction of the fuzzy rules can be time consuming and involve much fine tuning. The most effective industrial applications have been on processes which are inherently stable and the control actions are for keeping process variables within operational bounds, rather than accurate regulation or servo following.

A further popular application is the control of simple loops of the kind usually controlled using three-term (PID) controllers. The use of fuzzy logic here is to emulate the PID action, often with some modifications to accommodate non-linear plant behavior. Figure 1 shows how a fuzzy logic system replaces the conventional controller in this form of application. Note that the fuzzy inference engine in the diagram will consist of a set of fuzzy rules.

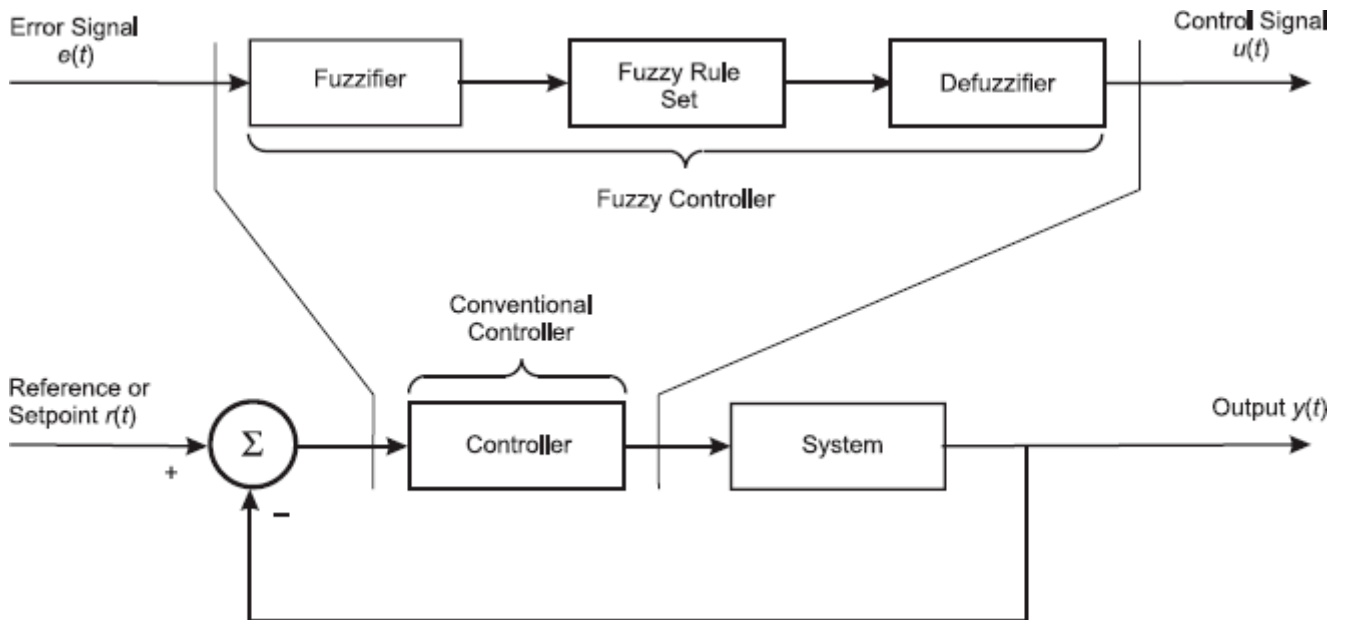

Figure 1: Fuzzy Controller

Main Apparatus:

- CE124 Fuzzy Logic Trainer (figure 2).
- CE103 Thermal Control Process apparatus (figure 3).
- CE105 Coupled Tanks apparatus (figure 4).

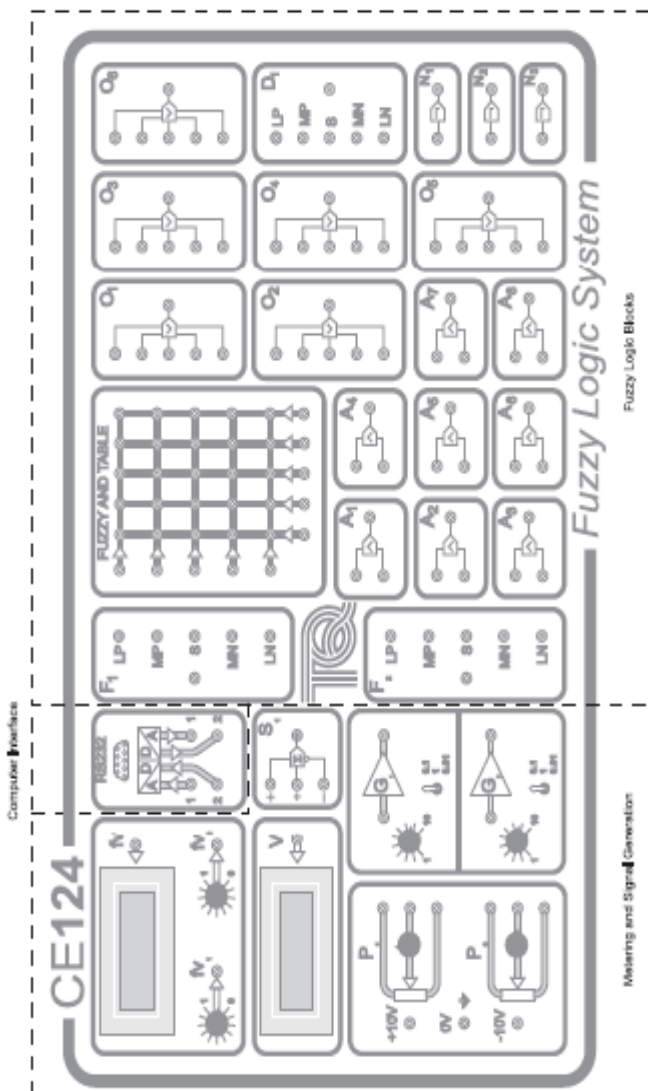

Figure 2: CE124 Fuzzy Logic Trainer

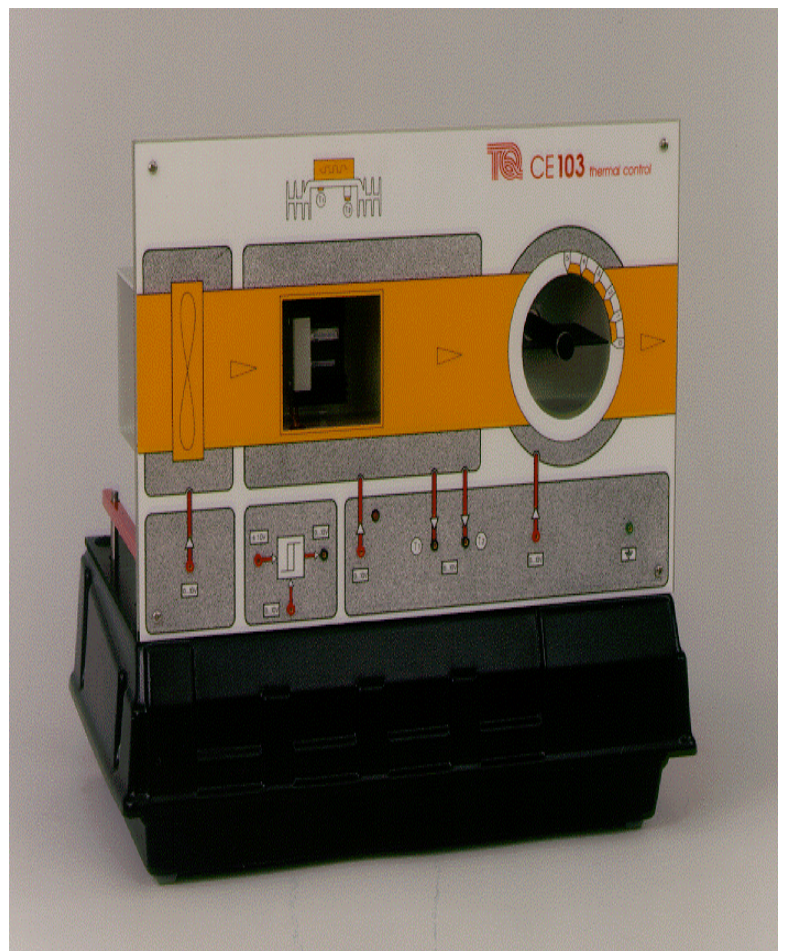

Figure 3: CE103 Thermal Control Process Apparatus



Figure 4: CE105 Coupled Tanks Apparatus

Part 1: Fundamentals of Fuzzy Logic

The objective of this part is to investigate the basic principles of fuzzy logic including the following:

- How signals and voltages are converted or classified into fuzzy variables by fuzzifier blocks.
- How fuzzy variables are converted back into real signals by a defuzzifier block.
- The actions of the fuzzy logic operators: AND, OR and NOT.

A. Fuzzy Membership

- Connect the equipment as shown in figure 5.
- With a potentiometer output of -10 V, measure the classifier outputs using the fuzzy variable meter connected to the outputs LP (large positive), MP (medium positive), S (small), MN (medium negative) and LN (large negative).
- Increase the potentiometer output and repeat the above procedure for different values of potentiometer output.
- Record your results in table 1 and draw a block diagram for the experimental setup.

Table 1

Input Voltage V	LP Degree of membership	MP Degree of membership	S Degree of membership	MN Degree of membership	LN Degree of membership
-8.2					
-3.5					
0					
+3.7					
+9.2					

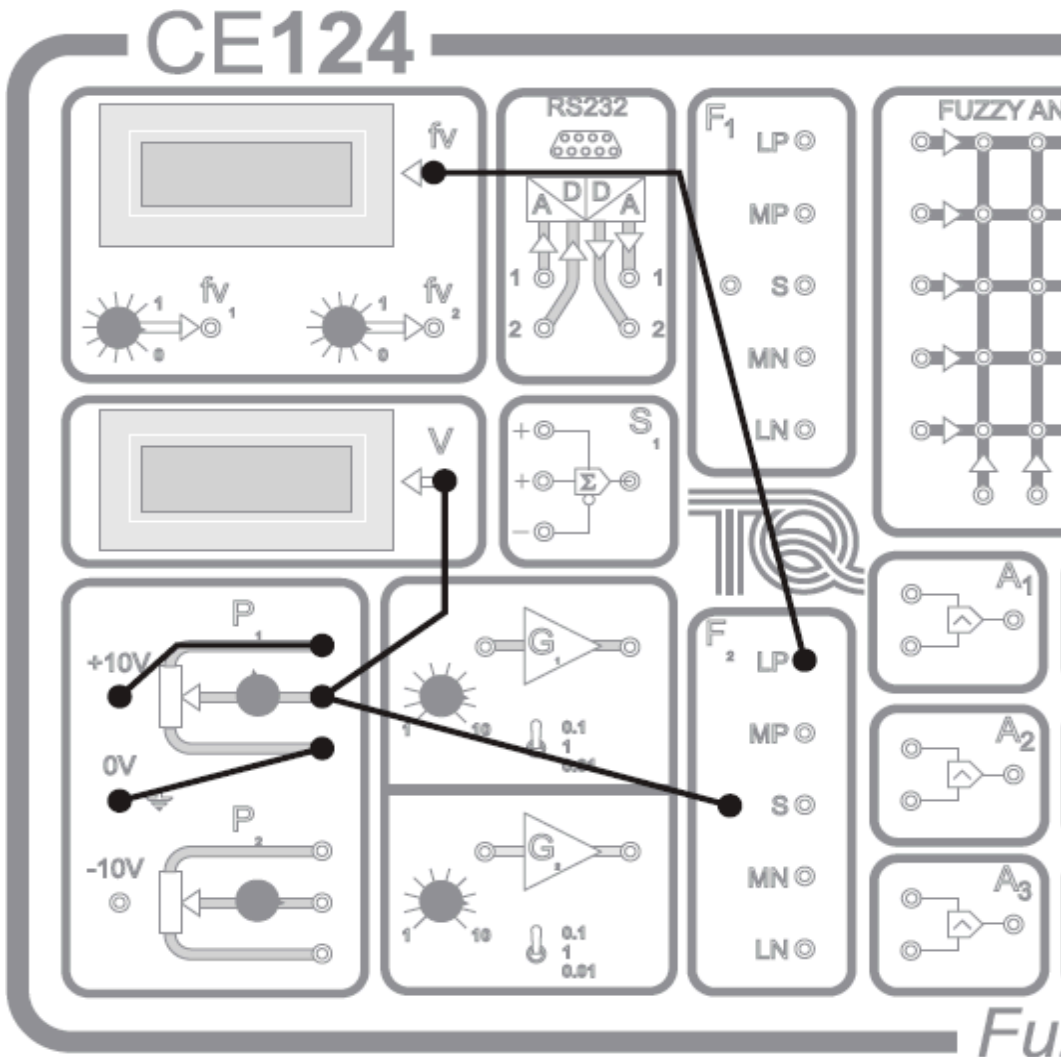

Figure 5: Fuzzy Membership

B. Defuzzification

- Connect the equipment as shown in figure 6, including the dotted connection.
- Set the fuzzy variable potentiometer fv_1 to zero (fully anticlockwise) and the fuzzy variable potentiometer fv_2 to one (fully clockwise).
- Check that the fuzzy variable fv_2 is connected to defuzzifier input MP (this is the dotted connection in figure 6). Increase the fuzzy variable fv_1 from 0 to 1, while decrease the fuzzy variable fv_2 from 1 to 0 by step of 0.2, then record the readings.
- Try to repeat the previous step to the rest of the defuzzifier inputs if you have free time!

Table 2

FV1	FV2	Output
S=0.6	MP=0.4	
MP=0.5	LP=0.5	
LN=0.7	?	
S=0.8	MN=0.2	
MN=1	??	

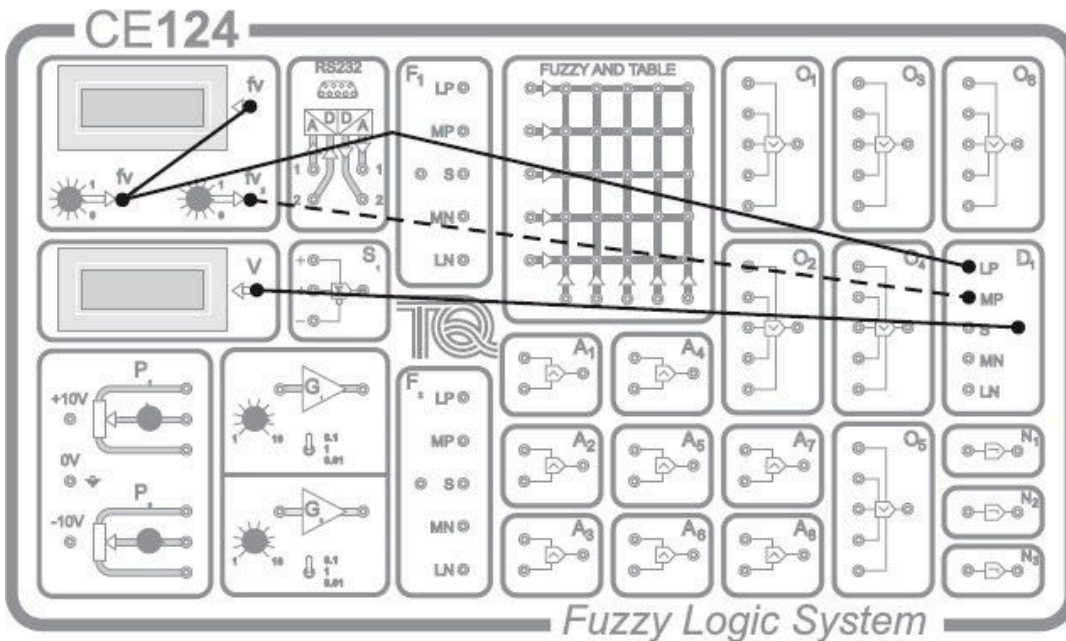

Figure 6: Defuzzification

C. Fuzzy Logic Operators: AND, OR, NOT

- Connect the apparatus as shown in figure 7 using the solid connection only.
- Set each of the fuzzy variables to a certain value from (0-1), and record it in table 3. Note the reading of the fuzzy variable at the output of the fuzzy AND block and record it.
- Insert the output of the fuzzy AND block to a fuzzy NOT block (shown as shadow connections in figure 7). Note its effect on the fuzzy voltmeter value compared with the previous results.
- Repeat the previous procedure for the fuzzy OR block by altering the connection of fv1 and fv2 to the fuzzy OR block.
- Use your results to write relations that define the fuzzy AND, OR and NOT operations.

Table 3

Operation	FV1	FV2	Output	Output with not
AND	0.2	0.8		
OR	0.2	0.8		

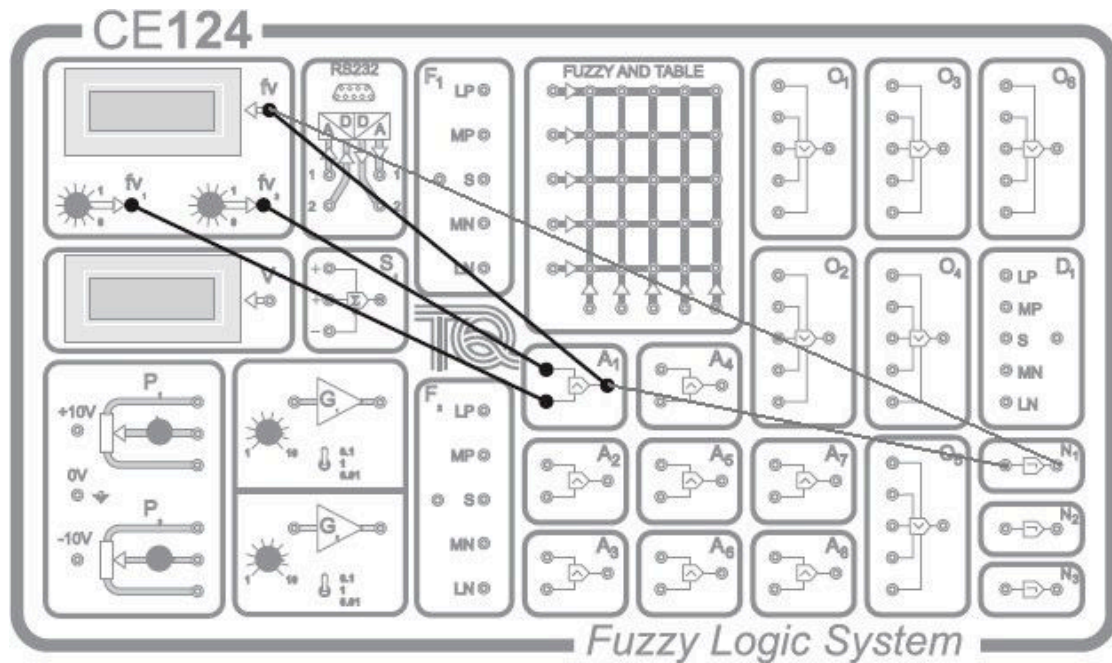

Figure 7: Fuzzy Logic Operator

Part 2: Proportional Control of the Thermal Control Process

The object of this exercise is to investigate fuzzy logic control applied to the thermal control process. The control is based on a fuzzy form of proportional (P) algorithm. The potentiometer P1 will be used to provide the reference (set-point) signal. The defuzzier output u is the control signal which is sent to the system input (the heater). The control signal is defuzzified from the fuzzy control law according to the classification:

- a) Large negative control=-10 V
- b) Medium negative control=-5 V
- c) Small control=0 V
- d) Medium positive control=5 V
- e) Large positive control=10 V

- Complete the following rule set so that it operate in a similar manner to a conventional proportional controller:

Rule 1: If {error LN} THEN {control _____}

Rule 2: If {error MN} THEN {control _____}

Rule 3: If {error S} THEN {control _____}

Rule 4: If {error MP} THEN {control _____}

Rule 5: If {error LP} THEN {control _____}

The abbreviations used in this rule set are LN= large negative, LP=large positive, S=small, MN=medium negative, and MP= medium positive.

- Connect the apparatus as shown in figure 8 and complete the second half of connection to represent the fuzzy rule set written above, and then connect the output of the defuzzifier to the heater input on CE103.

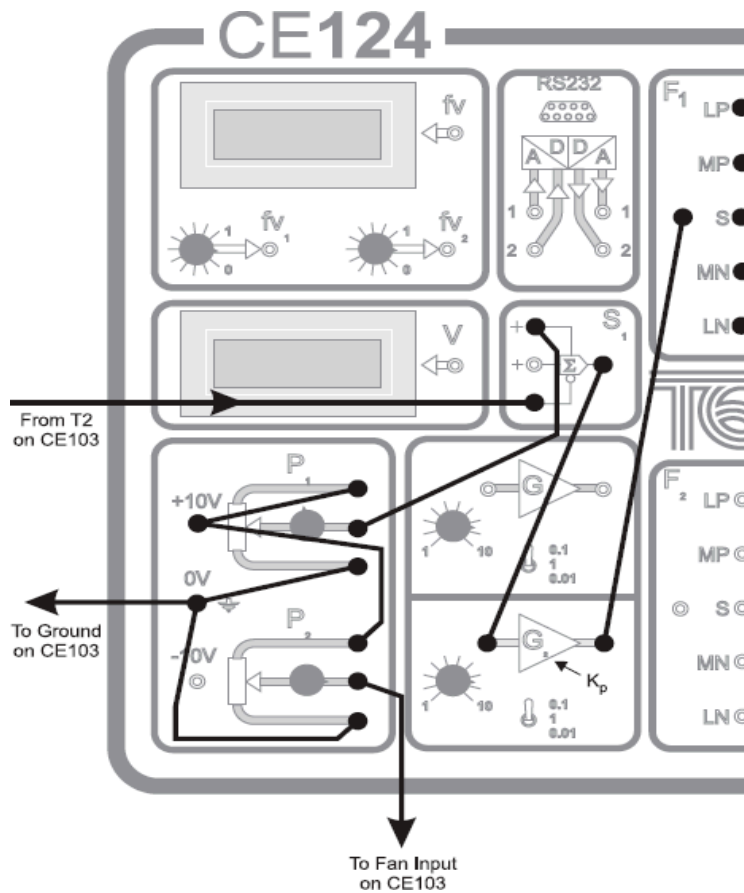

Figure 8: Fuzzy Control Wiring Diagram 1

- Apply the following initial settings:
 - Set potentiometer P1 to 4 V and P2 to 3 V.
 - Pre-process gain K_p set to 10.
 - Output shutter of CE103 fully open.
- With P1 producing a set point (or reference) of 4 V, record the temperature output T2. After the temperature has settled to the desired value, increase the set point to 6 V and again record the output. After the temperature has settled to the desired value, decrease the set point to 4 V and again record the output. Observe the output of the fuzzy controller and compare it with what you expect from a conventional controller.
- Vary the gain K_p and monitor the effect upon the system response.
- Sketch a block diagram of the fuzzy control system which is used in this part. Compare the results from the fuzzy control system and what you would expect from a conventional proportional system.

APPENDIX A

A commonly used fuzzification procedure converts the signal x into five levels. Thus:

- a) LP: x is large positive
- b) MP: x is medium positive

- c) S: x is small
- d) MN: x is medium negative
- e) LN: x is large negative

In a practical situation these membership functions may be represented symbolically by a single quinary fuzzifier as shown in figure 1.

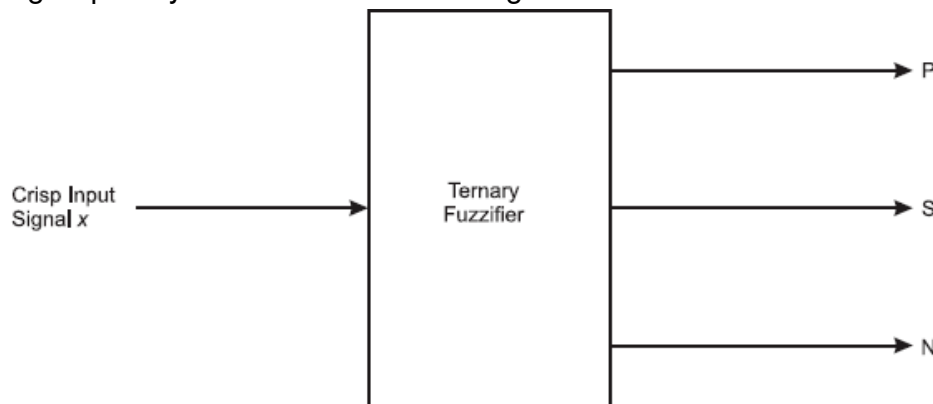

Figure 1: Fuzzifier for a Five-Level Fuzzy Classification System

The fuzzy membership sets can be shown on a single figure by overlaying the membership functions one on the top of another. The normal way which membership functions (for the five-level fuzzification) are shown is given in figure 2

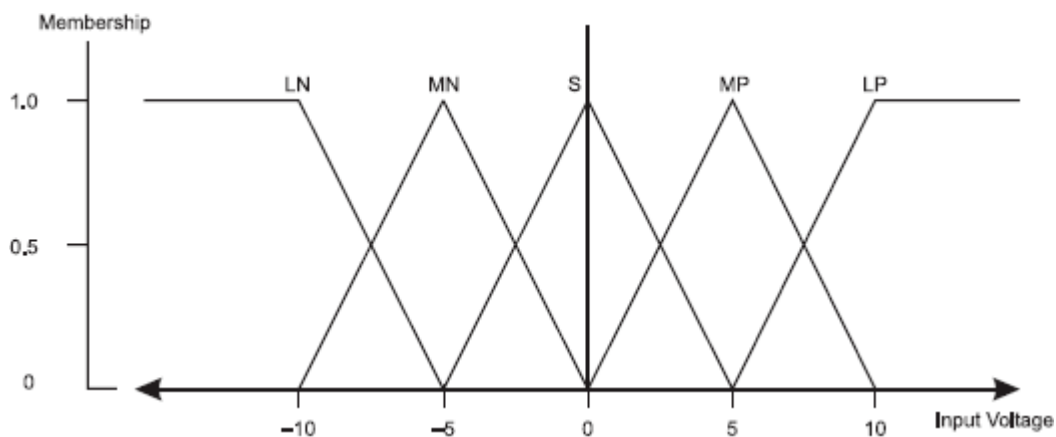

Figure 2: Fuzzy Membership Functions for a Five Level Fuzzifier

The membership function used so far is triangular. This was chosen because it is an easy shape to specify and is widely used in practice. However, it is important to appreciate that any reasonable shape can be used for the membership function to meet the requirements of specific applications. Alternative membership function shapes include: exponential, trapezoidal and cosine bell functions. Note that the shape of the membership function only affects the fuzzification stage and, from now on, it will be assumed that a triangular shape is used.